

COMBINED BEARINGS

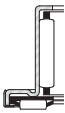

Technical features

Types of combined bearings

Nadella combined needle bearings type **RAX** and derivatives are designed to support simultaneously both a radial and an axial load.

They comprise a needle thrust bearing (or roller thrust bearing) and needle cage retained in a common outer ring.

The technical characteristics of the thrust bearing and the needle cage are set out in the appropriate sections. These bearings form one integral unit permitting easy storage, handling and fitting. Their high radial and axial load capacities and small space requirement enable cost effective solutions to be achieved.

Calculations for combined bearings are carried out taking the axial component and the radial component separately without transforming the axial load into an equivalent radial load.

The operation of the thrust bearing and the needle cage independent of one another precludes any interaction harmful to precise axial and radial rotation. Axial expansion of the shaft, for example, will have no effect on the accuracy of the radial component.

The bearings can be used without inner rings or thrust plates, if the shaft journals serving as raceways are of sufficient hardness and possess a suitable surface finish. Hardness of 58-64 HRC will ensure that the full capacity of these bearings is attained.

Lower hardness figures will entail a reduction in the static and dynamic capacities (both axial and radial) as shown in the tables of dimensions (see Technical Section).

TYPES OF BEARINGS

Standard combined bearings

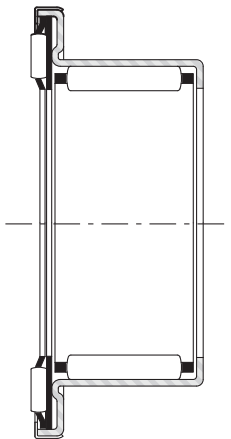

RAX700

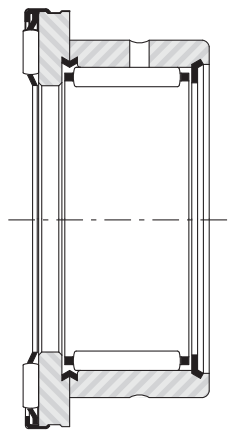

RAX400

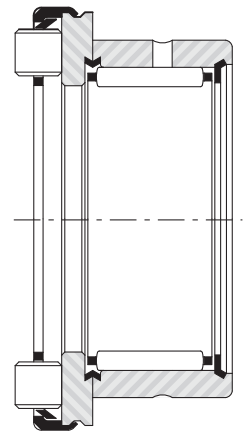

RAX500

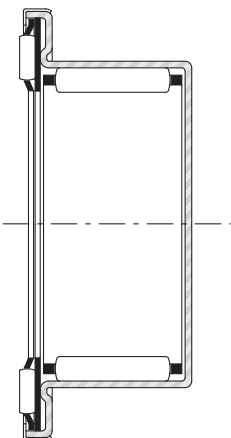

RAXF700

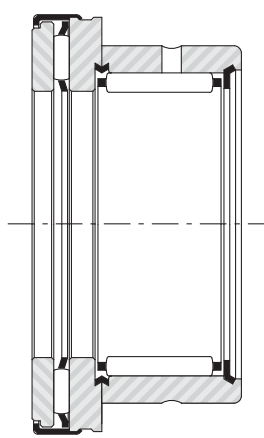

RAXPZ400

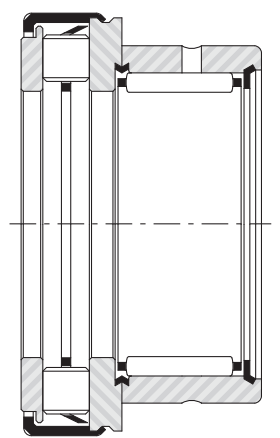

RAXZ500



Technical features

Types of combined bearings

Combined bearings type RAX 700 and RAXF 700

Combined bearings type **RAX 700** possess a one-piece outer ring formed from thin sheet steel accurately controlled and hardened by suitable heat treatment. The shape of this outer ring prevents weakness in the area between the axial component and the radial component, even after the latter has been tightly fitted into a housing.

This type of combined bearing is inexpensive and occupies little space, thus providing a very economical solution. Because they are easy to use and can be fitted rapidly, they are often employed in preference to an arrangement with two separate needle bearings.

Closed-end combined bearings type **RAXF 700** ensure perfect sealing at the end of a shaft and do not require the use of blind housings or end caps.

Standard combined bearings type RAX 400 and RAX 500

Combined needle bearings type **RAX 400** and **RAX 500** comprise a thrust plate and an outer ring machined separately and joined by a strong metal insert. This arrangement prevents localised stresses and weakness in the area between the two components, thus eliminating the risk of damage during mounting or operation.

Although combined bearings type **RAX 700** should be considered first on grounds of economy, combined bearings with thick outer ring type **RAX 400** or **RAX 500** should be used when operating conditions require higher limit loads or greater rotational accuracy. Moreover, they can be supplied in machine-tool quality type **RAXN**.

Standard combined bearings type RAXPZ 400 and RAXZ 500

These bearings have an incorporated thrust plate retained by a steel ring set on the thrust plate. They are better protected against the introduction of dust and metal particles and are therefore recommended for spindles of drilling machines.

	With needle thrust bearing				With roller thrust bearing	
	Thin outer ring		Thick outer ring		Thick outer ring	
	open	Closed-end	Without retained thrust Plate	With retained thrust plate	Without retained thrust plate	With retained thrust plate
Bearings	RAX 700	RAXF 700	RAX 400	RAXPZ 400	RAX 500	RAXZ 500
Separate thrust plates	CP thick or thin		CP thick or thin		CP thick or thin	
Inner rings ⁽¹⁾	JR		JR		JR	

(1) Inner rings with oil hole type **JR...JS1** on request.

Machine-tool quality combined bearings types RAXN 400, RAXN 500, and derivatives

The combined bearings in the **RAXN 400** and **RAXN 500** series are manufactured to the same dimensions as the **RAX 400** and **RAX 500** series in higher precision with respect to out-of-roundness and thickness of the rings and axial run-out of the thrust bearing. These bearings, which are also available with retained thrust plate **RAXNPZ 400** and **RAXNZ 500**, are particularly recommended for use in drilling machine spindles.

	With needle thrust bearing		With roller thrust bearing	
	Without thrust plate	With retained thrust plate	Without thrust plate	With retained thrust plate
Bearings	RAXN 400	RAXNPZ 400	RAXN 500	RAXNZ 500
Separate thrust plates	CPN		CPN	
Inner ring	IM 19 000 IM 20 600		IM 20 600	

Technical features

Types of combined bearings

TOLERANCES OF COMBINED BEARINGS

Combined bearings types RAX 700 and RAXF 700

Because types RAX 700 and RAXF 700 have an outer ring formed from thin sheet steel, the radial component of these bearings can only be inspected using a ring-gauge having sufficient thickness to withstand deformation and with a bore ground with great accuracy. The diameters of the ring-gauge and the "GO" and "NO-GO" plug-gauges are identical to those given on page 58 in the inspection table for caged needle bushes type DL having identical inner and outer diameters.

Thickness tolerance of the axial component C_1 : $\pm 0,1$ mm

Standard combined bearings type RAX 400, RAX 500 and derivatives

- *Radial component*

Diameter under the needles F_w : tolerance F6 (ISO Standard 1206).

Outer diameter D
Out-of-roundness
Inner rings JR

Normal tolerance class according to ISO Standard 1206 (see table on page 219).

- *Axial component*

Thickness C_1 : $+ 0,05/ - 0,06$ mm
Axial run-out max: 0,01 mm

Tolerance	Thin thrust plates		Thick thrust plates mm
	Internal \varnothing $d \leq 60$ mm	Internal \varnothing $d > 60$ mm	
Thickness	$h \pm 0,030$ ⁽¹⁾	$h \pm 0,050$ ⁽²⁾	$h \pm 0,050$
Max axial run-out	0,020 ⁽¹⁾	0,025 ⁽²⁾	0,005

(1) Under minimum load of 150 N - (2) Under minimum load of 250 N

Machine-tool quality combined bearings types RAXN 400, RAXN 500 and derivatives

- *Radial component*

Diameter under the needles F_w : tolerance F6 (ISO Standard 1206).

Outer diameter D: Normal tolerance class according to

ISO Standard 1206 (see table on page 219).

Out-of-roundness: Precision class 5 according to ISO Standard 492 (DIN 620) (see table on page 219).

Inner rings IM 19000 and IM 20600:

inner diameter d: 0/-0,010mm
outer diameter F: 0/ -0,005 mm
width B: 01/ -0,130 mm up to $d = 40$ mm
0/ -0,160 mm for $d > 40$ mm

out-of-roundness: 0.005 mm.

- *Axial component*

Thickness C_1 : 0/ -0,012 mm
Axial run-out: 0,005 mm

- *Thrust plates*

Thickness h: selected to obtain tolerance h8 on total thickness ($h + C_1$)
Axial run-out: 0,005 mm.

RADIAL PLAY

Combined bearings types RAX 700, RAXF 700

The fit of a combined bearing with thin outer ring in the housing determines, to a large extent, the dimension under the needles and consequently the radial play during operation.

The recommended shaft and housing tolerances give a radial play whose limits are suitable for most normal applications. To obtain a closer clearance, it is possible to match the shaft diameters with the diameters under the needles of the bearings, after the latter have been fitted into their housings.

The possible differences in the stiffness of housings and the variations of clamping force resulting from the tolerance build up do not permit to establish a range of dimensions under the needles for every application. However, for housings of very thick steel, taking into account the probable restraining force, the variations of the dimensions under the needles after installation will be within the tolerances

given below:

+ 15/ + 50 μ m up to $F_w = 20$ mm
+ 20/ + 60 μ m up to $F_w = 25$ a $F_w = 40$ mm
+ 20/ + 65 μ m up to $F_w = 45$ mm

Technical features

Types of combined bearings

The limits of radial play should also take into account the tolerance of the shaft used directly as a raceway or of the outer diameter of the inner ring after it has been fitted on to the shaft.

Where an inner ring is used on a shaft of recommended tolerance k5 (or m5), the minimum play may be slightly lower and the maximum play slightly higher than for the case of an assembly without inner ring on a shaft with tolerance h5.

Standard combined bearings type RAX 400, 500 and derivatives

Bearings without inner ring

The radial play of these bearings when used without inner rings is the difference between the diameter under the needles, which is kept within tolerance F6, and the diameter of the shaft which is machined to the recommended tolerances.

This type of combined bearing without inner ring can be supplied having a diameter under the needles selected in the lower half of tolerance F6 (suffix **TB**) or in the upper half (suffix **TC**) according to the table below.

Nominal dimension		Tolerance of diameter under the needles		
F _w mm		Normal F6 µm	TB µm	TC µm
above	to			
da 6	a 10	+13/+22	+13/+18	+ 17/+22
da 10	a 18	+16/+27	+16/+22	+21/+27
da 18	a 30	+20/+33	+20/+27	+26/+33
da 30	a 50	+25/+41	+25/+33	+33/+41
da 50	a 80	+30/+49	+30/+40	+39/+49

Bearings with inner ring

The radial play prior to installation of standard combined bearings with inner ring is in conformance with the normal group of ISO Standard 5753. The closely controlled play provided by this standard can be provided on request.

Machine-tool quality combined bearings types RAXN 400, 500 and derivatives

Bearings without inner ring

The radial play prior to installation of machine-tool quality combined bearings results from tolerance F5 on the diameter under the needles, possibly in selection **TB** or **TC**, and tolerances k5 on the diameter of the shaft.

Nominal dimension		Tolerance of diameter under the needles
F _w mm		F5 µm
above	to	
da 6	a 10	+13/+19
da 10	a 18	+16/+24
da 18	a 30	+20/+29
da 30	a 50	+25/+36
da 50	a 80	+30/+43

Bearings with inner ring

The radial play prior to installation of machine-tool quality combined bearings results from tolerance F5 on the diameter under the needles and tolerance 0/-0.005 mm on the outer diameter F_w of inner ring **IM 19000** or **IM 20600**.

SHAFT AND HOUSING TOLERANCES

Combined bearings	Shaft				Housing	
	Quota F _w per cuscinetti senza anello interno		Dimension d for bearings with inner ring		Dimension D	
	Rotation	Oscillation	Rotation	Oscillation	Steel or cast-iron	Non-ferrous metal (1) or thin castings in steel
RAX, RAXF 700	h5 (h6)	j5 (j6)	k5 (k6)	m5 (m6)	H6 (H7)	M6 (M7)
RAX, RAXPZ, RAXZ series 400 and 500	h5	j5	k5	m5	K6	M6
RAXN, RAXNPZ RAXNZ series 400 and 500	k5	k5	k5	m5	K6	M6

1) If a housing of non-ferrous metal reaches temperatures considerably higher (or lower) than 20°C, account should be taken of the difference in expansion (or contraction) of the outer race of the bearing and suitable adjustments to the fits should be made.

The cylindrical tolerance defined as the difference in radii of two coaxial cylinders (ISO Standard 1101) should normally be less than a quarter of the manufacturing tolerance.

However, for high precision or high speed applications, it is advisable to restrict this tolerance to the one-eighth of the manufacturing tolerance.

Technical features

Types of combined bearings

SUPPORTING FACES- RACEWAYS

The bearing shoulder must be a flat face at right angles to the housing axis, otherwise axial precision will be affected and the smooth running characteristics of the thrust bearing will be diminished.

Similarly, the shaft shoulder, on which the needles of the thrust bearing rotate or on which the thrust plate is supported, must be flat and square to the axis.

The deviation from true parallelism between the two supporting faces must be no more than:

- 0.3 in 1000, corresponding to an angle of 1 minute, for a combined bearing with thrust plate.
- 0.45 in 1000, corresponding to an angle of 1' 30", for a combined bearing without thrust plate.

In the case of an assembly where neither thrust plate nor inner ring is used, the shaft journal on which the needle rotate must have sufficient hardness, i.e. 58-64 HRC to ensure maximum load capacities are attained.

If the shaft shoulder is used directly as a raceway for the needles of the thrust bearing or, if it supports a thin thrust plate (thickness 0.8 or 1.5 mm), it must be rigid and continuous throughout the area of circulation of the needles bounded by dimensions E_b and E_a .

A thick thrust plate can be supported on a smaller shaft shoulder or on one that is discontinuous (as in the case of splines), provided the deflection of the plate does not affect the smooth running or required accuracy of the thrust bearing.

INSTALLATION

The bearing must be correctly aligned with the housing. It is wise to use a small press fitted with a mandrel having a supporting face square to the axis and covering the whole area bounded by dimensions E_b and E_a . This method prevents the thrust component from undergoing shock load which might damage the bearing.

When **RAX** or **RAXF 700** bearings are placed in position during installation care must be taken to ensure that the force exerted by the press does not exceed the axial limit load shown in the table of dimensions.

The fitting of inner rings on shafts manufactured to the recommended tolerances is usually sufficient to render the use of retaining rings unnecessary. However, if it is necessary to employ a ring to support an adjacent pinion, this ring must have an outer diameter slightly smaller than dimension F_w to enable it to pass smoothly into the bearing when the shaft is introduced.

TYPICAL ARRANGEMENTS USING COMBINED BEARINGS

RAX and **RAXF 700**: see page 162.

RAX 400 (or **500**) and **RAXPZ 400** (or **RAXZ 500**): see page 163.

RAXN 400 (or **500**) and **RAXNPZ 400** (or **RAXNZ 500**): the typical applications for these machine-tool quality combined bearings used without inner ring and with or without thick thrust plate are identical to those for the corresponding standard combined bearings (see page 163).

The special inner rings (series **19000** or **20600**) designed for machine-tool quality combined bearings are of sufficient width to permit centring of the thrust plate and thus eliminate the need for a shaft shoulder.

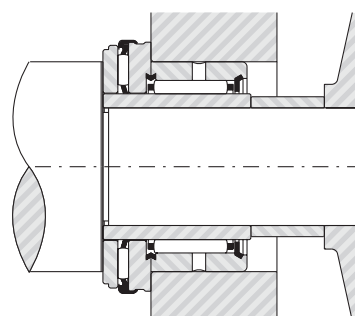
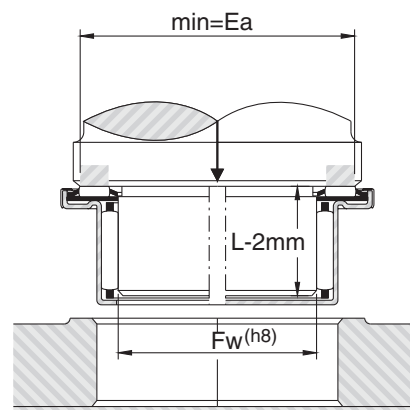

Technical features

Types of combined bearings

LUBRICATION

When the applied axial loads are relatively high and the application allows the use of oil as the desired method of lubrication, bearing types **RAX 500** should be given consideration. Combined bearings with a dust cap may use oil lubrication, although their design makes them better suited for use with grease lubrication.

Combined bearings are typically shipped protected with a corrosion preventive compound that is not a lubricant. The bearings may be used in oil or grease lubricated applications, without removal of the corrosion-preventive compound. However, it may be advisable to remove the corrosion-preventive compound before packing the bearings (with a suitable grease) to obtain optimum grease performance and to minimize the possibility of confusing grease bearings with bearings containing corrosion preventive.

LOAD RATINGS

Calculations for combined bearings are carried out taking the axial component and the radial component separately without transforming the axial load into an equivalent radial load.

For the meaning of the Load Ratings in the tables of combined bearings **RAX 400**, **RAX 500** and derivatives, see the Technical Section.

Combined bearings type **RAX700** and **RAXF700** has a limitation for the maximum axial permissible load, both axial and radial, because are made in thin outer ring. Limit loads are in the table on page 165.

Methods of installation for combined bearings RAX and RAXF 700

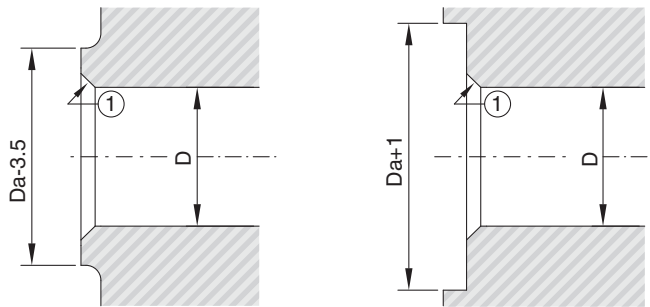

(1) Chamfer: 0,5 to 1 mm up to RAX (or RAXF) 720
0,7 to 1,5 mm from RAX (or RAXF) 725

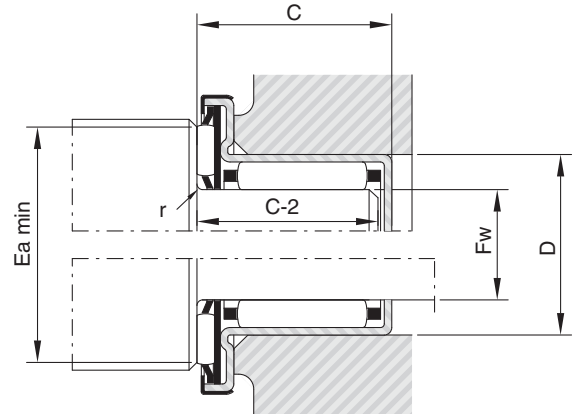

RAX RAXF	712	714	715	718	720	725	730	735	740	745
r max. mm	0.75	1	1.8	1	0.5	1.8	1.8	1.8	0.5	0.5

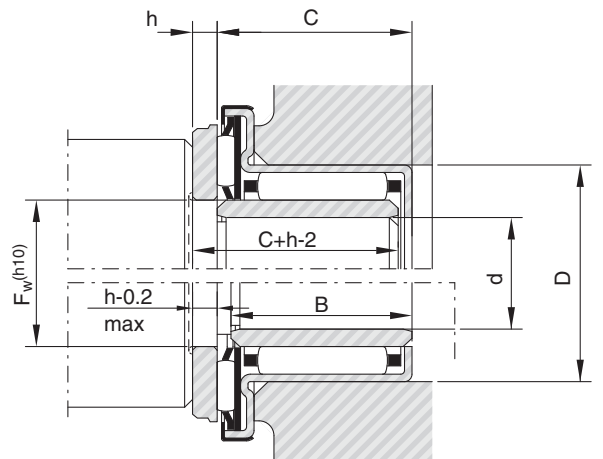
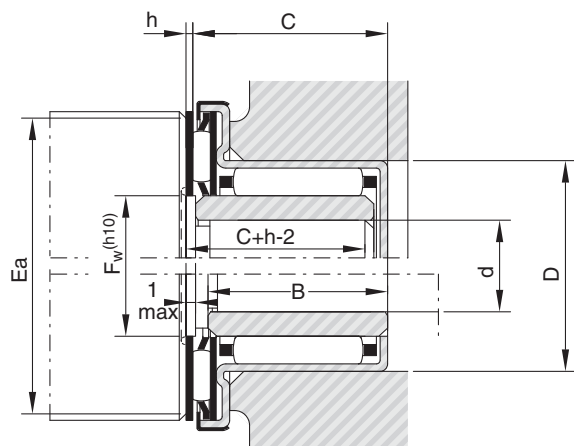
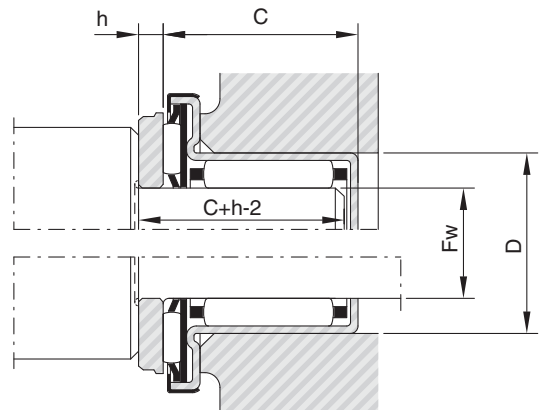
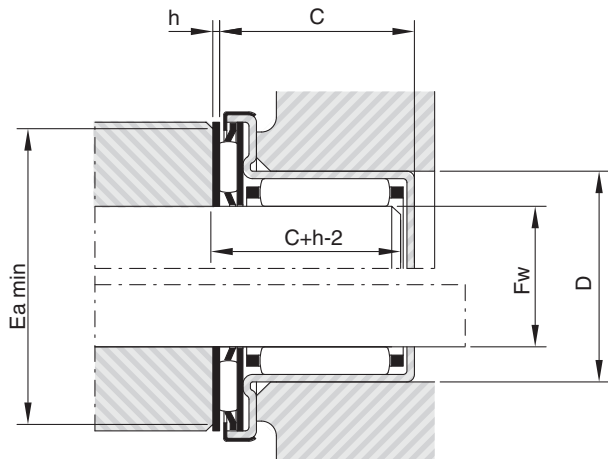

Methods of installation for combined bearings RAX 400 and 500, RAXPZ 400 and RAXZ 500

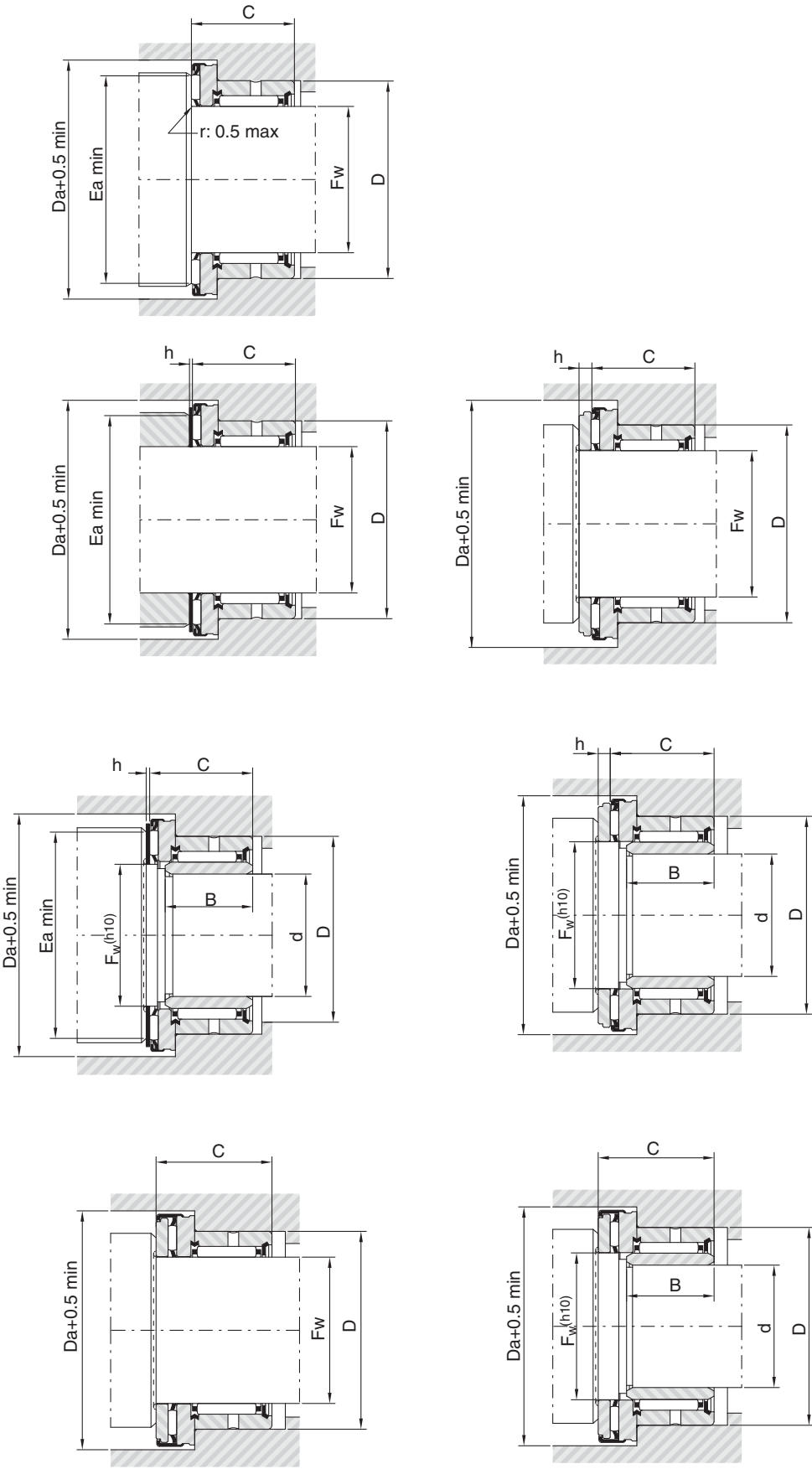

Combined bearings RAX 700

- open RAX 700 series
- closed-end RAXF 700 series

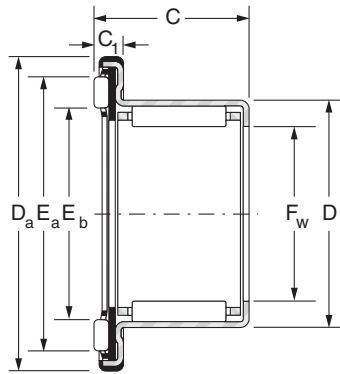

RAX 700

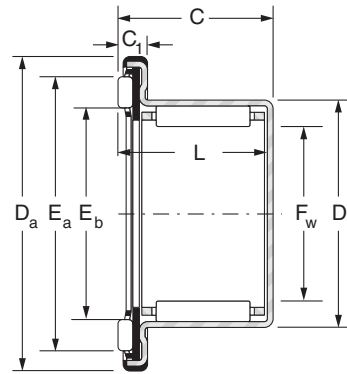

RAXF 700

Shaft ∅ mm	Designations		F _w mm	D mm	C mm	D _a mm	E _b mm	E _a mm	C ₁ mm	L mm	Load ratings kN			
	RAX 700 series	RAXF 700 series									Radial		Axial	
											Dyn. C	Stat. C ₀	Dyn. C	Stat. C ₀
5	RAX 705		5	9	11	15.5	7.2	11.2	3.3	–	2.15	1.95	3.15	6.35
12	RAX 712	RAXF 712	12	18	14.2	27.5	15	22.6	4.2	13.2	6.30	7.20	6.90	17.7
14	RAX 714	RAXF 714	14	20	14.2	29.5	17	24.6	4.2	13.2	6.90	8.50	7.40	20.0
15	RAX 715	RAXF 715	15	21	14.2	31.5	19	26.6	4.2	13.2	7.40	9.30	7.80	22.0
18	RAX 718	RAXF 718	18	24	18.2	33.5	21	28.6	4.2	17.2	11.5	17.7	8.00	23.0
20	RAX 720	RAXF 720	20	26	18.2	36.5	22	31.6	4.2	17.2	12.2	19.5	11.8	39.0
25	RAX 725	RAXF 725	25	33	22.2	45.5	30	39.6	4.2	21.2	20.5	32.0	13.7	52.0
30	RAX 730	RAXF 730	30	38	22.2	50.5	35	44.7	4.2	21.2	22.3	37.5	14.9	60.0
35	RAX 735		35	43	22.2	56.5	39	50.9	4.2	21.2	24.5	45.0	19.4	88.0
40	RAX 740	RAXF 740	40	48	22.2	61.5	43	54.9	4.2	21.2	26.2	51.0	20.4	96.0
45	RAX 745		45	52	22.2	66.5	48	59.9	4.2	21.2	24.8	55.0	21.8	109

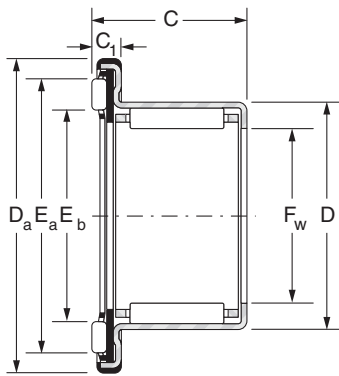

RAX 700

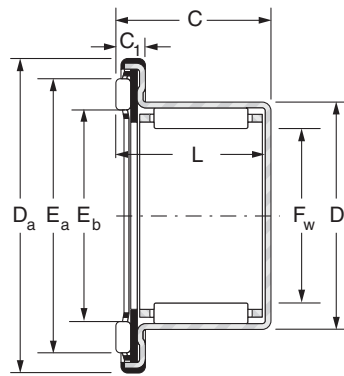

RAXF 700

Limit Loads kN		Speed rating min ⁻¹	Weight		Inspection			Inner ring	Thrust plate		Shaft Ø mm
Radial	Axial		RAX Kg	RAXF Kg	Housing Ø mm	GO plug-gauges mm	NO-GO plug-gauges mm		Thin	Thick	
0.74	3.5	25000	0.005		9.000	5.009	5.036				5
2.5	11	13000	0.017	0.018	18.000	12.009	12.035	JR 8x12x12.5	CP 12 26	CP 2 12 26	12
2.9	12.5	11500	0.018	0.020	20.000	14.009	14.035	JR 10x14x12	CP 14 26	CP 2 14 26	14
3.1	14	10500	0.020	0.022	21.000	15.009	15.035	JR 12x15x12.5	CP 15 28	CP 2 15 28	15
5.8	16	10000	0.027	0.030	24.000	18.009	18.035	JR 15x18x16.5	CP 18 30	CP 2 18 30	18
6.4	18	9000	0.031	0.035	26.000	20.009	20.035	JR 15x20x16	CP 20 35	CP 3 20 35	20
10.5	22	7200	0.055	0.060	33.000	25.015	25.041	JR 20x25x20.5	CP 25 42	CP 3 25 42	25
12	25	6300	0.063	0.070	38.000	30.015	30.041	JR 25x30x20.5	CP 30 47	CP 3 30 47	30
14.3	27	5500	0.075	0.084	43.000	35.015	35.041	JR 30x35x20.5	CP 35 52	CP 3 35 52	35
16	30	5000	0.086	0.096	48.000	40.015	40.041	JR 35x40x20.5	CP 40 60	CP 3 40 60	40
17	32	4500	0.088	0.099	52.000	45.015	45.041	JR 40x45x20.5	CP 45 65	CP 3 45 65	45

Combined bearings RAX 400 – RAX 500

Machine-tool
quality combined
bearings
RAXN 400,
RAXN 500
series

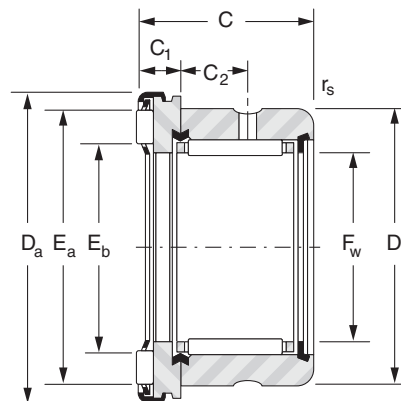

RAX 400 - RAXN 400

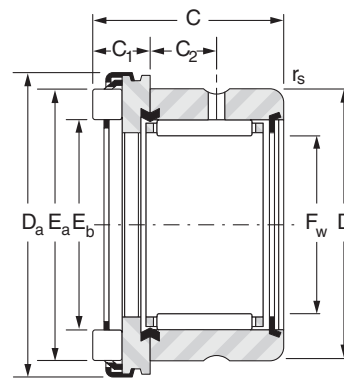

RAX 500 - RAXN 500

Shaft ∅ mm	Designations		F _w mm	C mm	D mm	D _a mm	E _b mm	E _a mm	C ₁ mm	C ₂ mm	r _{s min} mm
	RAX 400 series	RAX 500 series									
10	RAX 410		10	19	19	22	12	18.6	5	6	0.35
		RAX 510	10	19.5	19	22	12.2	18.5	5.5	6	0.35
12	RAX 412		12	19	21	26	15	22.6	5	6	0.35
		RAX 512	12	20	21	26	22.9	14.8	6	6	0.35
15	RAX 415		15	19	24	28	17	24.6	5	6	0.35
		RAX 515	15	20	24	28	16.8	24.9	6	6	0.35
17	RAX 417		17	21	26	30	19	26.6	5	8	0.65
		RAX 517	17	22	26	30	18.8	26.9	6	8	0.65
20	RAX 420		20	24	30	35	22	31.6	6	9	0.85
		RAX 520	20	26	30	35	22	31.6	8	9	0.85
25	RAX 425		25	24	37	42	27.7	37.4	6	9	0.85
		RAX 525	25	26	37	42	27.7	37.4	8	9	0.85
30	RAX 430		30	24	42	47	32.7	42.4	6	9	0.85
		RAX 530	30	26	42	47	32.7	42.3	8	9	0.85
35	RAX 435		35	24	47	53	37.2	49	6	9	0.85
		RAX 535	35	27	47	53.4	37.8	47.8	9	9	0.85
40	RAX 440		40	24	52	60	43	54.9	6	9	0.85
		RAX 540	40	28	52	60.4	54.8	42.8	10	9	0.85
45	RAX 445		45	24	58	65	48	59.9	6	9	0.85
		RAX 545	45	28	58	65.4	47.8	59.8	10	9	0.85
50	RAX 450		50	27	62	70	53.3	65.7	6	11	1.3
		RAX 550	50	31	62	70.4	52.8	64.8	10	11	1.3
60	RAX 460		60	28	72	85	63.5	79.2	7	11	1.3
		RAX 560	60	32	72	85.4	63.5	79.5	11	11	1.3
70	RAX 470		70	28	85	95	73.5	89.2	7	11	1.3
		RAX 570	70	32	85	95.4	73.5	89.5	11	11	1.3

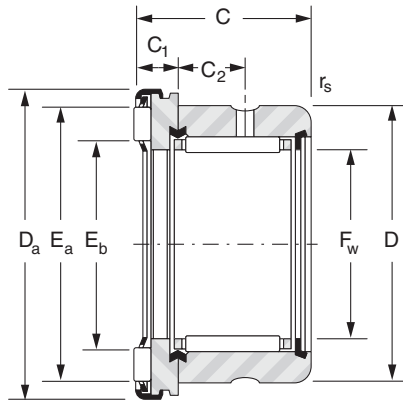

RAX 400 - RAXN 400

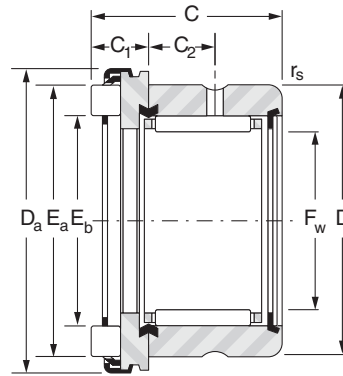

RAX 500 - RAXN 500

Load Ratings kN				Speed Rating min ⁻¹	Weight kg	Inner ring	Thrust plate		Shaft Ø mm
Radial		Axial					Thin	Thick	
Dyn. C	Stat. Co	Dyn. C	Stat. Co						
5.90	7.16	5.00	10.9	15500	0.025	JR 7x10x16	CP 10 22	CP 2 10 22	10
5.90	7.16	8.20	17.9	15500	0.026	JR 7x10x16	CP 10 22	CP 2 10 22	
6.78	9.03	7.10	18.5	13000	0.032	JR 9x12x16	CP 12 26	CP 2 12 26	12
6.78	9.03	12.7	29.5	13000	0.033	JR 9x12x16	CP 12 26	CP 2 12 26	
9.66	12.6	7.60	20.8	11500	0.034	JR 12x15x16	CP 15 28	CP 2 15 28	15
9.66	12.6	14.0	34.0	11500	0.036	JR 12x15x16	CP 15 28	CP 2 15 28	
11.8	16.3	8.10	23.0	10500	0.041	JR 14x17x17	CP 17 30	CP 2 17 30	17
11.8	16.3	15.0	39.0	10500	0.044	JR 14x17x17	CP 17 30	CP 2 17 30	
14.8	23.7	11.8	39.0	9000	0.066	JR 17x20x20	CP 20 35	CP 3 20 35	20
14.8	23.7	22.0	54.0	9000	0.070	JR 17x20x20	CP 20 35	CP 3 20 35	
15.1	26.2	13.3	49.0	7500	0.099	JR 20x25x20	CP 25 42	CP 3 25 42	25
15.1	26.2	25.5	70.0	7500	0.105	JR 20x25x20	CP 25 42	CP 3 25 42	
20.2	34.6	14.5	57.0	6500	0.111	JR 25x30x20	CP 30 47	CP 3 30 47	30
20.2	34.6	26.5	77.0	6500	0.118	JR 25x30x20	CP 30 47	CP 3 30 47	
22.1	40.8	18.9	84.0	5500	0.130	JR 30x35x20	CP 35 52	CP 3 35 52	35
22.1	40.8	33.8	94.0	5500	0.146	JR 30x35x20	CP 35 52	CP 3 35 52	
23.8	47.0	20.4	96.0	5000	0.150	JR 35x40x20	CP 40 60	CP 3 40 60	40
23.8	47.0	46.0	129.0	5000	0.174	JR 35x40x20	CP 40 60	CP 3 40 60	
24.9	51.8	21.8	109.0	4500	0.179	JR 40x45x20	CP 45 65	CP 3 45 65	45
24.9	51.8	49.0	143.0	4500	0.206	JR 40x45x20	CP 45 65	CP 3 45 65	
30.2	68.5	22.5	118.0	4000	0.205	JR 45x50x25	CP 50 70	CP 3 50 70	50
30.2	68.5	51.0	157.0	4000	0.232	JR 45x50x25	CP 50 70	CP 3 50 70	
31.9	78.1	31.5	193.0	3500	0.282	JR 55x60x25	CP 60 85	CP 4 60 85	60
31.9	78.1	71.0	255.0	3500	0.327	JR 55x60x25	CP 60 85	CP 4 60 85	
36.1	84.7	34.5	223.0	3000	0.386	JR 60x70x25	CP 1.5 70 95	CP 4 70 95	70
36.1	84.7	77.0	295.0	3000	0.435	JR 60x70x25	CP 1.5 70 95	CP 4 70 95	

Combined bearings with incorporated thrust plate RAXPZ 400 – RAXZ 500

Machine-tool
quality combined
bearings
RAXNPZ 400,
RAXNZ 500
series

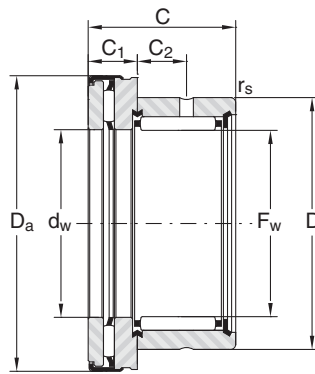

RAXPZ400 - RAXNPZ 400

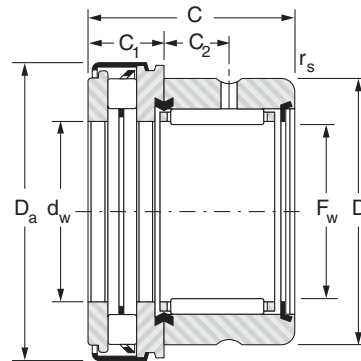

RAXZ 500 - RAXNZ 500

Shaft ∅ mm	Designations		F _w mm	D mm	C mm	d _a mm	D _a mm	C ₁ mm	C ₂ mm	r _{s min} mm
	RAXPZ 400 series	RAXZ 500 series								
10	RAXPZ 410		10	19	21	10	22.4	7	6	0.35
		RAXZ 510	10	19	21.5	10	22.4	7.5	6	0.35
12	RAXPZ 412		12	21	21	12	26.4	7	6	0.35
		RAXZ 512	12	21	22	12	26.4	8	6	0.35
15	RAXPZ 415		15	24	21	15	28.4	7	6	0.35
		RAXZ 515	15	24	22	15	28.4	8	6	0.35
17	RAXPZ 417		17	26	23	17	30.4	7	8	0.65
		RAXZ 517	17	26	24	17	30.4	8	8	0.65
20	RAXPZ 420		20	30	27	20	35.4	9	9	0.85
		RAXZ 520	20	30	29	20	35.4	11	9	0.85
25	RAXPZ 425		25	37	27	25	43	9	9	0.85
		RAXZ 525	25	37	29	25	43	11	9	0.85
30	RAXPZ 430		30	42	27	30	48	9	9	0.85
		RAXZ 530	30	42	29	30	48	11	9	0.85
35	RAXPZ 435		35	71	27	35	54	9	9	0.85
		RAXZ 535	35	47	30	35	54	12	9	0.85
40	RAXPZ 440		40	52	27	40	61	9	9	0.85
		RAXZ 540	40	52	31	40	61	13	9	0.85
45	RAXPZ 445		45	58	27	45	66	9	9	0.85
		RAXZ 545	45	58	31	45	66	13	9	0.85
50	RAXPZ 450		50	62	30	50	71	9	11	1.3
		RAXZ 550	50	62	34	50	71	13	11	1.3
60	RAXPZ 460		60	72	32	60	86	11	11	1.3
		RAXZ 560	60	72	36	60	86	15	11	1.3
70	RAXPZ 470		70	85	32	70	96	11	11	1.3
		RAXZ 570	70	85	36	70	96	15	11	1.3

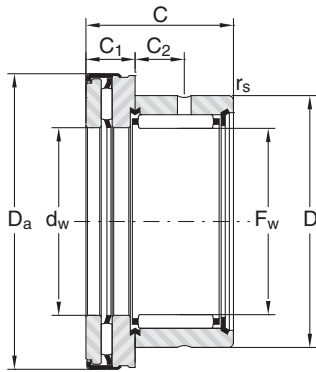

RAXPZ400 - RAXNPZ 400

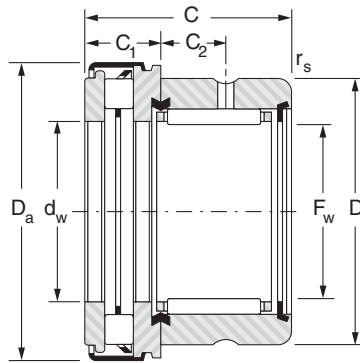

RAXZ 500 - RAXNZ 500

Load Ratings kN				Speed rating min ⁻¹	Weight kg	Shaft ∅ mm
Radial		Axial				
Dyn. C	Stat. Co	Dyn. C	Stat. Co			
5.9	7.2	5	10.9	15500	0.029	10
5.9	7.2	8.2	17.9	15500	0.031	
6.8	9	7.1	18.5	13000	0.038	12
6.8	9	12.7	29.5	13000	0.039	
9.66	12.6	7.6	20.8	11500	0.040	15
9.66	12.6	14	34	11500	0.044	
11.8	16.3	8.1	23	10500	0.048	17
11.8	16.3	15	39	10500	0.053	
14.8	23.7	11.8	39	9000	0.079	20
14.8	23.7	22	54	9000	0.086	
15.1	26.2	13.3	49	7500	0.118	25
15.1	26.2	25.5	70	7500	0.131	
20.2	34.6	14.5	57	6.500	0.133	30
20.2	34.6	26.5	77	6.500	0.147	
22.1	40.8	18.9	84	5.500	0.157	35
22.1	40.8	33.8	94	5.500	0.181	
23.8	47	20.4	96	5.000	0.184	40
23.8	47	46	129	5.000	0.218	
24.9	51.8	21.8	109	4.500	0.216	45
24.9	51.8	49	143	4.500	0.255	
30.2	68.5	22.5	118	4.000	0.245	50
30.2	68.5	51	157	4.000	0.287	
31.9	78.1	31.5	193	3.500	0.365	60
31.9	78.1	71	255	3.500	0.423	
36.1	84.7	34.5	223	3.000	0.479	70
36.1	84.7	77	295	3.000	0.545	

Thrust plates for standard combined bearings

CP thin and thick series

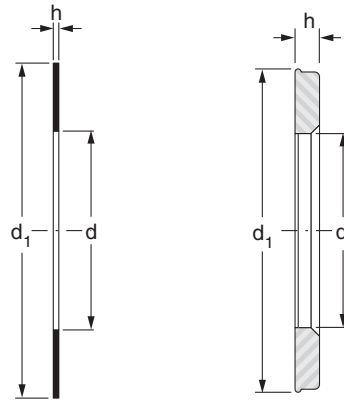

CP thin

CP thick

Shaft ∅ mm	Designations		d mm	d ₁ mm	h mm	Weight g	For combined bearings		
	CP Thin series	CF Thick series					RAX 700 RAXF 700	RAX 400	RAX 500
10	CP 10 22		10	21.5	0.8	1.7		RAX 410	RAX 510
		CP 2 10 22	10	21.5	2	4.3			
12	CP 12 26		12	25.5	0.8	2.5	RAX, RAXF 712	RAX 412	RAX 512
		CP 2 12 26	12	25.5	2	6.2			
14	CP 14 26		14	25.5	0.8	2.3	RAX, RAXF 714		
		CP 2 14 26	14	25.5	2	5.6			
15	CP 15 28		15	27.5	0.8	2.8	RAX, RAXF 715	RAX 415	RAX 515
		CP 2 15 28	15	27.5	2	6			
17	CP 17 30		17	29.5	0.8	2.5		RAX 417	RAX 517
		CP 2 17 30	17	29.5	2	7			
18	CP 18 30		18	29.5	0.8	2.3	RAX, RAXF 718		
		CP 2 18 30	18	29.5	2	5.7			
20	CP 20 35		20	34.5	0.8	3.8	RAX, RAXF 720	RAX 420	RAX 520
		CP 3 20 35	20	34.5	3	13			
25	CP 25 42		25	41.5	0.8	5.3	RAX, RAXF725	RAX425	RAX 525
		CP 3 25 42	25	41.5	3	19			
30	CP 30 47		30	46.5	0.8	6	RAX, RAXF 730	RAX 430	RAX 530
		CP 3 30 47	30	46.5	3	22			
35	CP 35 52		35	51.5	0.8	7	RAX, RAXF 735	RAX 435	RAX 535
		CP 3 35 52	35	51.5	3	26			
40	CP 40 60		40	59.5	0.8	9.3	RAX, RAXF 740	RAX 440	RAX 540
		CP 3 40 60	40	59.5	3	34			
45	CP 45 65		45	64.4	0.8	10	RAX, RAXF 745	RAX 445	RAX 545
		CP 3 45 65	45	64.4	3	37			
50	CP 50 70		50	69.4	0.8	11		RAX 450	RAX 550
		CP 3 50 70	50	69.4	3	40			
60	CP 60 85		60	84.3	0.8	17		RAX 460	RAX 560
		CP 4 60 85	60	84.3	4	83			
70	CP 1.5 70 95		70	94.3	1.5	32		RAX 470	RAX 570
		CP 4 70 95	70	94.3	4	93			



Inner rings for standard combined bearings

JR standard series

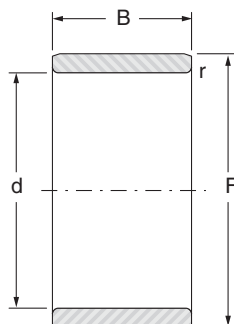

JR

Shaft ∅ mm	Designations		d mm	F mm	B mm	r mm	Weight g	For combined bearings		
	JR series	JR series						RAX 700 RAXF 700	RAX 400 RAXPZ 400	RAX 500 RAXZ 500
7		JR 7x10x16	7	10	16	0.2	4.8		RAX 410	RAX 510
8	JR 8x12x12,5		8	12	12.5	0.3	5.8	RAX 712		
9		JR 9x12x16	9	12	16	0.2	5.9		RAX 412	RAX 512
10	JR 10x14x12		10	14	12	0.3	7	RAX 714		
12	JR 12x15x12,5		12	15	12.5	0.2	5.8	RAX 715		
		JR 12x15x16	12	15	16	0.2	7.6		RAX 415	RAX 515
13	JR 15x18x16,5		13	18	16.5	0.35	15	RAX 718		
14		JR 14x17x17	14	17	17	0.2	9.3		RAX 417	RAX 517
15	JR 15x20 16		15	20	16	0.35	17	RAX 720		
		JR 17x20x20	15	20	20	0.35	20.5		RAX 420	RAX 520
20		JR 20x25x20	20	25	20	0.35	32		RAX 425	RAX 525
		JR 20x25x20,5	20	25	20.5	0.35	33	RAX 725		
25		JR 25x30x20	25	30	20	0.35	32		RAX 430	RAX 530
		JR 25x30x20,5	25	30	20.5	0.35	33	RAX 730		
30		JR 30x35x20	30	35	20	0.35	38		RAX 435	RAX 535
		JR 30x35x20,5	30	35	20.5	0.35	39	RAX 735		
35		JR 35x40x20	35	40	20	0.35	44		RAX 440	RAX 540
		JR 35x40x20,5	35	40	20.5	0.35	45	RAX 740		
40		JR 40x45x20	40	45	20	0.35	50		RAX 445	RAX 545
		JR 40x45x20,5	40	45	20.5	0.35	51	RAX 745		
45		JR 45x50x25	45	50	25	0.65	69		RAX 450	RAX 550
55		JR 55x60x25	55	60	25	0.65	84		RAX 460	RAX 560
60		JR 60x70x25	60	70	25	0.85	190		RAX 470	RAX 570

Thrust plates for machine-tool quality combined bearings

CPN series for
RAXN 400 and RAXN 500

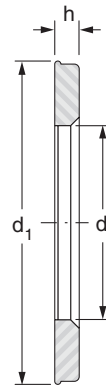

CPN

Centred		Designations		d mm	d ₁ mm	h mm	Weight kg
On shaft ∅ mm	On inner ring ∅ mm	CPN Standard series	CPN Supplementary series				
10		CPN 2 10 22		10	21.5	2	0.0043
			CPN 2,5 10 22	10	21.7	2.5	0.005
			CPN 4 10 22	10	21.7	4	0.009
12		CPN 2 12 26		12	25.5	2	0.0062
			CPN 3 12 26	12	25.7	3	0.0095
			CPN 4 12 26	12	25.7	4	0.012
15		CPN 2 15 28		15	27.5	2	0.006
			CPN 4 15 28	15	27.7	4	0.013
			CPN 7 15 28	15	27.7	7	0.024
17		CPN 2 17 30		17	29.5	2	0.007
			CPN 4 17 30	17	29.7	4	0.014
			CPN 7 17 30	17	29.7	7	0.025
20		CPN 3 20 35		20	34.5	3	0.013
			CPN 5 20 35	20	34.7	5	0.024
25		CPN 3 25 42		25	41.5	3	0.019
			CPN 5 25 42	25	41.77	5	0.033
30		CPN 3 30 47		30	46.5	3	0.022
			CPN 5 30 47	30	46.7	5	0.037
35		CPN 3 35 52		35	51.5	3	0.026
			CPN 4 35 52	35	52	4	0.034
40		CPN 3 40 60		40	59.5	3	0.034
45		CPN 3 45 65		45	64.4	3	0.037
50		CPN 3 50 70		50	69.4	3	0.040
60		CPN 4 60 85		60	84.3	4	0.083
70		CPN 4 70 95		70	94.3	4	0.093

Inner ring for machine-tool quality combined bearings

IM 19000 and IM 20600 series for RAXN 400 and RAXN 500

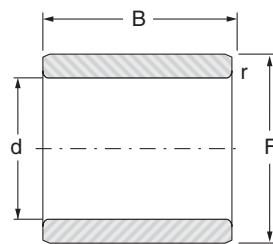

IM

Shaft ∅ mm	Designations		d mm	F mm	B mm	Weight kg
	IM 19 000 series	IM 20 600 series				
17	IM 19 017		17	20	27.5	0.019
		IM 20 617	17	20	31.5	0.021
20	IM 19 020		20	25	27.5	0.038
		IM 20 620	20	25	31.5	0.044
25	IM 19 025		25	30	27.5	0.042
		IM 20 625	25	30	31.5	0.048
30	IM 19 030		30	35	27.5	0.055
		IM 20 630	30	35	31.5	0.063
35	IM 19 035		35	40	27.5	0.063
		IM 20 635	35	40	31.5	0.072
40	IM 19 040		40	45	27.5	0.069
		IM 20 640	40	45	31.5	0.08
45	IM 19 045		45	50	30.5	0.085
		IM 20 645	45	50	34.5	0.096
50	IM 19 050		50	60	32.5	0.208
		IM 20 650	50	60	38.5	0.25
60	IM 19 060		60	70	32.5	0.247
		IM 20 660	60	70	39.5	0.30

Bearing assemblies

Combined bearings,
thrust plates, inner rings
machine-tool
quality series
RAXN, RAXNPZ 400,
RAXN, RAXNZ 500

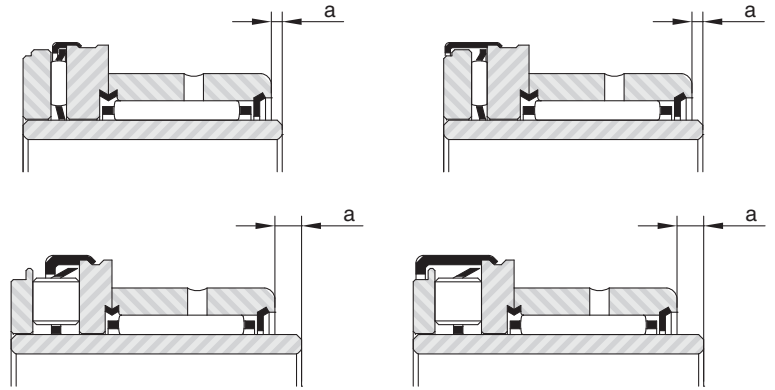

Combined bearings and separate thrust plates	Combined bearings with retained thrust plates	Inner rings	a mm
RAXN 420 + CPN 3 20 35	RAXNPZ 420	IM 19 017	0.5
		IM 20 617	4.5
RAXN 420 + CPN 5 20 35		IM 20 617	2.5
RAXN 520 + CPN 3 20 35	RAXNZ 520	IM 20 617	2.5
RAXN 520 + CPN 5 20 35		IM 20 617	0.5
RAXN 425 + CPN 3 25 42	RAXNPZ 425	IM 19 020	0.5
		IM 20 620	4.5
RAXN 425 + CPN 5 25 42		IM 20 620	2.5
RAXN 525 + CPN 3 25 42	RAXNZ 525	IM 20 620	2.5
RAXN 525 + CPN 5 25 42		IM 20 620	0.5
RAXN 430 + CPN 3 30 47	RAXNPZ 430	IM 19 025	0.5
		IM 20 625	4.5
RAXN 430 + CPN 5 30 47		IM 20 625	2.5
RAXN 530 + CPN 3 30 47	RAXNZ 530	IM 20 625	2.5
RAXN 530 + CPN 5 30 47		IM 20 625	0.5
RAXN 435 + CPN 3 35 52	RAXNPZ 435	IM 19 030	0.5
		IM 20 630	4.5
RAXN 435 + CPN 4 35 52		IM 20 630	3.5
RAXN 535 + CPN 3 35 52	RAXNZ 535	IM 20 630	1.5
RAXN 535 + CPN 4 35 52		IM 20 630	0.5

Bearing assemblies

Combined bearings,
thrust plates, inner rings
machine-tool
quality series
RAXN, RAXNPZ 400,
RAXN, RAXNZ 500

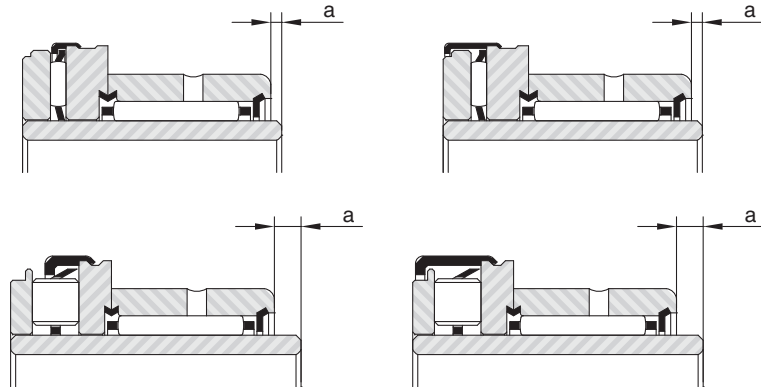

Combined bearings and separate thrust plates	Combined bearings with retained thrust plates	Inner rings	a mm
RAXN 440 + CPN 3 40 60	RAXNPZ 440	IM 19 035	0.5
		IM 20 635	4.5
RAXN 540 + CPN 3 40 60	RAXNZ 540	IM 20 635	0.5
RAXN 445 + CPN 3 45 65	RAXNPZ 445	IM 19 040	0.5
		IM 20 640	4.5
RAXN 545 + CPN 3 45 65	RAXNZ 545	IM 20 640	0.5
RAXN 450 + CPN 3 50 70	RAXNPZ 450	IM 19 045	0.5
		IM 20 645	4.5
RAXN 550 + CPN 3 50 70	RAXNZ 550	IM 20 645	0.5
RAXN 460 + CPN 4 60 85	RAXNPZ 460	IM 19 050	0.5
		IM 20 650	6.5
RAXN 560 + CPN 4 60 85	RAXNZ 560	IM 20 650	2.5
RAXN 470 + CPN 4 70 95	RAXNPZ 470	IM 19 060	0.5
		IM 20 660	7.5
RAXN 570 + CPN 4 70 95	RAXNZ 570	IM 20 660	3.5