

PRECISION COMBINED BEARINGS, WITH ADJUSTABLE AXIAL PRELOAD



NADELLA

Technical features

Precision combined bearings



Types **AXNB** and **ARNB** combined bearings and their derivatives consist of a radial needle bearing with cage, in an outer race, with a high radial thickness, each face of which acts as a raceway for a needle or roller thrust bearing. The inner ring, secured laterally between the thrust plates, acts as the inner radial raceway. Combined bearings type **AXNA**, have the same features of previous, but the radial needle bearing is without cage.

These bearings which take up very little space, are particularly recommended for shafts requiring very precise axial positioning, operating under high load, such as leading spindles, ballscrews for numerically-controlled machine tools, drive shafts on control apparatus, etc.

DESIGNATIONS

	With attachment holes	Radial caged bearings	Thrust bearing	
			needle	roller
AXNA AXNAT	●		● ●	
AXNB AXNBT	●	● ●	● ●	
ARNB ARNBT	●	● ●		● ●

TYPES OF PRECISION COMBINED BEARINGS

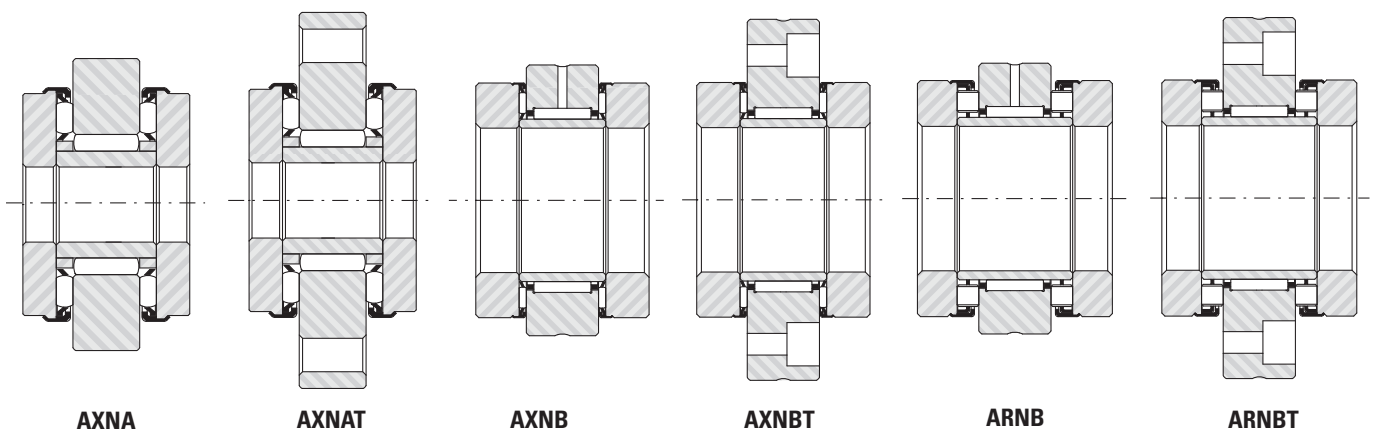

AXNA

AXNAT

AXNB

AXNBT

ARNB

ARNBT



Technical features

Precision combined bearings

SELECTION OF BEARING TYPE

Subject to calculations made for each application, the following general classifications can be made:

AXNB and AXNBT bearings for slow speed assemblies with low operating loads; the particularly high axial rigidity of needle thrust bearings, together with the advantages of preloading, ensure a very high axial precision and satisfactory working life.

For example: displacement drive shafts on control apparatus.

ARNB and ARNBT, series 1 and 2 bearings generally enable preloading to be chosen which suit the precision and working life required of production machine tools.

ARNB series 3 bearings for machine tools, machining units or special equipment requiring very high axial rigidity with high loads and slow speeds.

PRELOAD

This technique consists in subjecting the thrust bearings to controlled preload during assembly, using an adjusting nut, in order to eliminate play and reduce the axial displacement caused by the operating stress regardless of the direction or the axial load.

In an assembly with an axial preload of F_0 , an operating stress F_1 overloads one of the thrust bearings and frees the other of a load approximately equal to $F_1/2$. In an assembly without preload, the loaded thrust bearing must carry the entire stress F_1 .

In a preloaded assembly, the axial rigidity is therefore approximately twice that of an assembly without preload. This result is obtained as long as the operating stress F_1 remains less than about twice the preload stress F_0 . When $F_1 > 2 F_0$, one of the thrust bearings is total freed and the other thrust bearing completely carries the load F_1 ; in this case, the axial run-out remains less than it would have been for an assembly without preload (see figure).

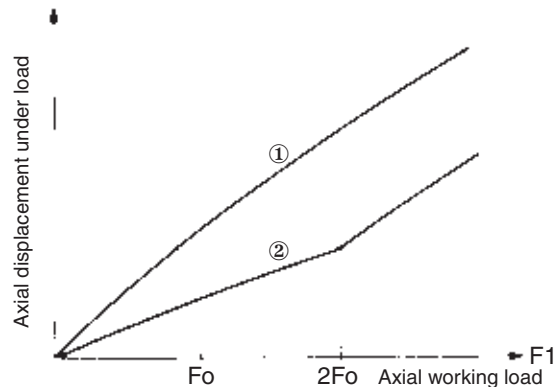

- (1) thrust bearing without preload
(2) thrust bearing under a preload F_0

DETERMINING OF PRELOAD

Preload F_0 should be determined according to the axial precision required under maximum load and the working life required.

The working life of the thrust bearing carrying the greater load depends on the resulting stress applied (i.e. $F_0 + F_1/2$ when $F_1 < 2 F_0$ or when $F_1 > 2 F_0$). Since these two cases can both occur on the same machine according to the type of machining carried out, the calculations must take into account the running time ratios under the various loads and speeds.

For more usual assemblies, a preload stress of 5 to 10% of the axial dynamical load carrying capacity of the thrust bearing, is usually suitable.

For certain applications, with slow rotating speeds, for example, the preload stress can be increased to allow for a higher operating load while remaining within the limit of the preload effect, and achieving a satisfactory working life.

ADJUSTMENT OF PRELOAD

For a given assembly, the shaft torque is defined first, which corresponds to the preload required.

Series adjustments can then be made on each machine by simply checking the torque.

If, as a result of assembly, this is not possible, the nut tightening torque needed to obtain preload is determined separately on the test assemblies. The torque must then be respected for series adjustments. The torque must be measured after starting up the thrust bearing, since it can be up to 50% higher at the beginning of rotation.

Technical features

Precision combined bearings

BEARING TOLERANCES

The outer and inner rings of the combined bearings are manufactured with class 6 tolerances according to ISO Standard 492 (class P6 of standard DIN 620).

The radial play before assembly is kept within the limits of group 2 given for inner and outer paired rings according to ISO Standard R 5753 (class C2 "paired rings" of standard DIN 620).

The axial run-out of the thrust bearing plates is in accordance with tolerance class 4 according to ISO Standard 199 (class P4 of standard DIN 620).

ASSEMBLY RECOMMENDATIONS

Shaft tolerance: g5 on dimension Di.

Tolerance of outer ring housing: J6 on dimension De.

The bearing parts of the thrust bearings must be rigid, with plane faces, perpendicular to the rotation axis and of very good surface quality to avoid crushing during use as this decreases the preloading. Their outside diameter must be at least equal to the average diameter of the race, dimension Dm. The outer ring of the combined bearings should be blocked against a shoulder in order to avoid any axial displacement under load.

In type **AXNA**, **AXNB** and **ARNB** bearings, they are usually blocked by a spacer positioned lengthways during assembly. A flange attached by screws to the frame is located against the spacer (flange and spacer can be in a single piece).

The outer ring of type **AXNBT** and **ARNBT** bearings has three attachment screw holes for direct attachment to the frame.

The surface finish of the outer diameter of the thrust bearing plates (dimension D_A) allows the sliding of the seal rings.

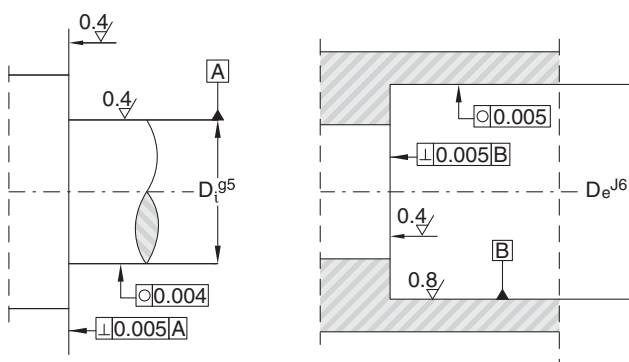

LUBRICATION

The oil used to lubricate the other parts of the assembly is generally suitable for combined bearings whose outer ring has three 120° holes connected by a groove. Grease can generally be used if the rotating speed is in the order of 50% of the maximum speeds given in the dimensional tables. However, special top quality greases enable higher speeds to be reached. By way of information, oils with viscosities of 30 to 150 cSt are recommended.

EXAMPLES OF CALCULATIONS

Choice of bearing

P = stress under which precision is needed

P < 2 x Preloading

In this field of preloading, the axial rigidity is equal to 2K

The interference is $\frac{1}{2K} P$

Example: If P = 7000 N, ARNB 50 90 will be chosen, since the preloading value is 3800 N and 2 x 3.800 = 7.600N > P

Rigidity in this field k = 2 K = 3900 N/μm⁻¹

Under P, the interference will be

$$\frac{1}{3.900} \times 7.000 = 1,79 \mu\text{m}$$

WORKING LIFE

The hypotheses given in the table below enable the equivalent speed and an equivalent load to be determined according to the maximum load and maximum speed, which enables a rapid calculation of the theoretical working life to be made under average operating conditions.

	1	2	3	4
Loads	P _{max}	0,8 x P _{max}	0,5 x P _{max}	0,2 x P _{max}
Speeds	0,05 V _{max}	0,2 V _{max}	0,5 V _{max}	V _{max}
Time %	0,15	0,40	0,30	0,15

Calculation of equivalent speed:

$$V_{eq} = (0,15 \times 0,05 + 0,40 \times 0,2 + 0,30 \times 0,5 + 0,15) V_{max} = 0,39 \times V_{max}$$

Calculation of the equivalent load:

$$P_{eq} \approx \sqrt[10]{P_{max}^p \times V_{max} (0,0075 + 0,08 \times 0,8^p + 0,15 \times 0,5^p + 0,15 \times 0,2^p)}$$

$$0,39 \times V_{max}$$

$$P_{eq} \approx 0,575 \times P_{max}$$

$$p = 10/3$$

Technical features

Precision combined bearings

ROTATION TORQUE IN FUNCTION OF PRELOAD

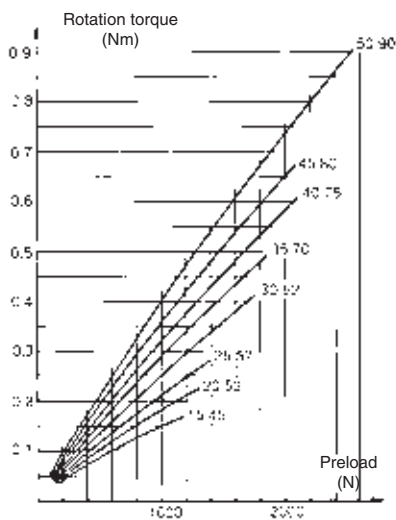

AXNB

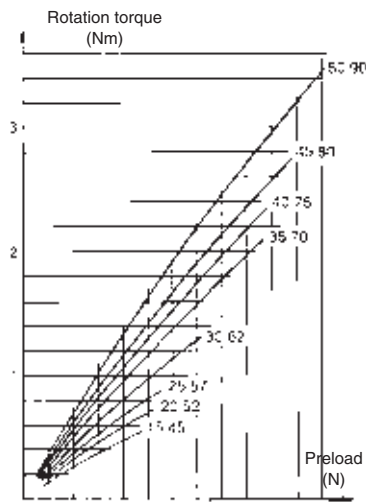

ARNB serie 1

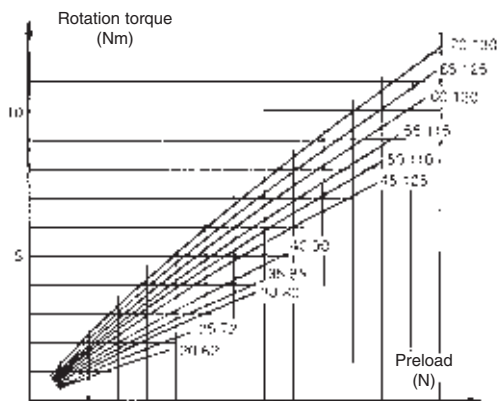

ARNB serie 2

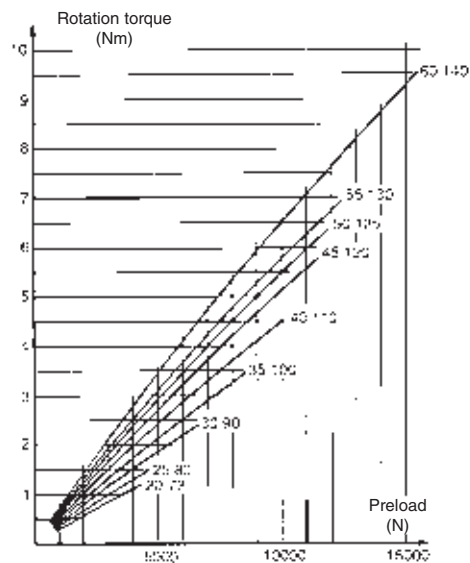

ARNB serie 3

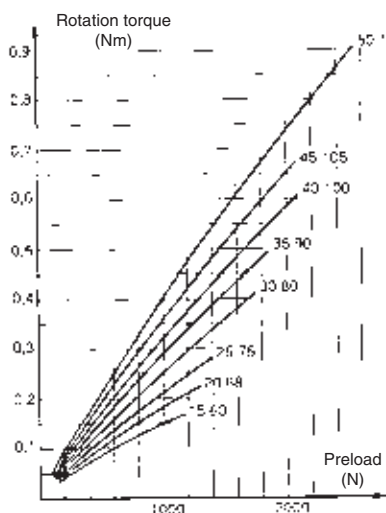

AXNBT

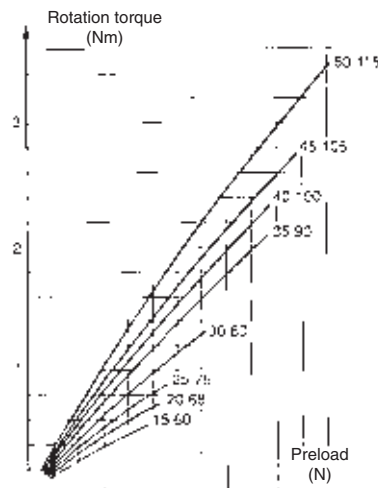

ARNBT serie 1

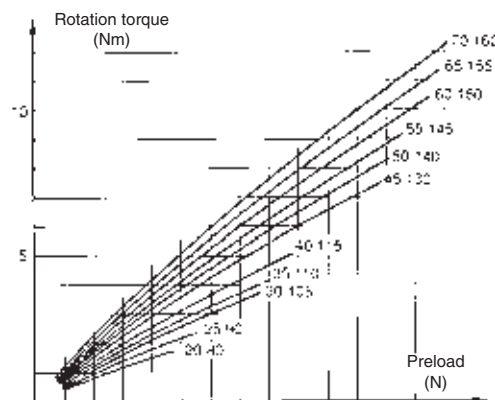

ARNBT serie 2



Precision combined bearings, with adjustable axial preload

AXNA and AXNAT series

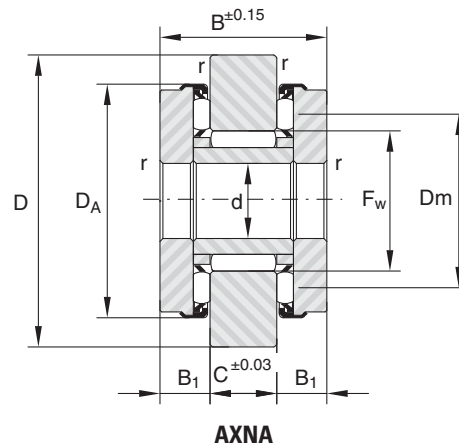

Shaft ∅ mm	Designation		d mm	D mm	F _w mm	D _A mm	D _m mm	B mm	C mm	B ₁ mm	r min.	Mounting			
	AXNA	AXNAT										Screw TCEI ⁴⁾ class 12.9	N° screws	E mm	Torque Nm
5	5 22		5	22	7.3	17	12.5	12	4	4	0.35				
		5 32	5	32	7.3	17	12.5	12	4	4	0.35	3 x 10	4	24	1.4
6	6 28		6	28	8.7	22	15.3	16	6	5	0.35				
		6 38	6	38	8.7	22	15.3	16	6	5	0.35	4 x 12	4	30	3
7	7 32		7	32	11.1	26	18.8	18	6	6	0.35				
		7 42	7	42	11.1	26	18.8	18	6	6	0.35	4 x 12	6	34	3
8	8 32		8	32	11.1	26	18.8	18	6	6	0.35				
		8 42	8	42	11.1	26	18.8	18	6	6	0.35	4 x 12	6	34	3
9	9 35		9	35	12.8	28	20.8	20	8	6	0.35				
		9 45	9	45	12.8	28	20.8	20	8	6	0.35	4 x 16	6	37	3
10	10 37		10	37	14.1	30	22.8	22	8	7	0.35				
		10 48	10	48	14.1	30	22.8	22	8	7	0.35	5 x 16	6	39	6
12	12 40		12	40	16.6	32	24.8	22	8	7	0.35				
		12 50	12	50	16.6	32	24.8	22	8	7	0.35	5 x 16	6	41	6

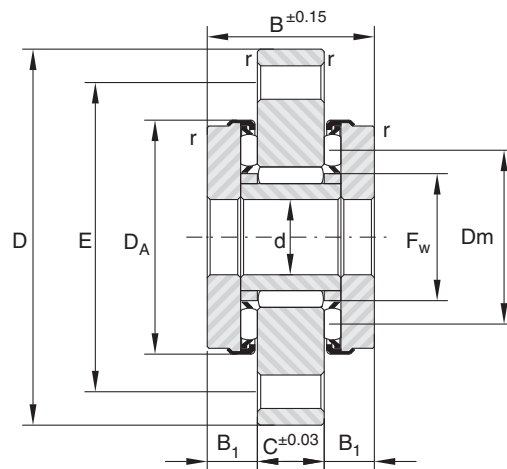

AXNAT

Load Ratings kN				Speed Ratings min ⁻¹	Preload 1) N	Rotation 2) torque Nmm	Rigidity K 3) N/μm	Shaft threading	Weight kg	Designation
radial		axial								
Dyn. C	Stat. Co	Dyn. C	Stat. Co							
2.35	2.65	4.0	9.4	19 000	252	55	32	5 x 0,8	0.021	AXNA 5 22
2.35	2.65	4.0	9.4	19 000	252	55	32	5 x 0,8	0.032	AXNAT 5 32
4.9	5.8	7.2	17.5	15 500	340	70	50	6 x 1	0.045	AXNA 6 28
4.9	5.8	7.2	17.5	15 500	340	70	50	6 x 1	0.064	AXNAT 6 38
5.8	7.4	7.9	21.0	13 000	469	130	100	7 x 1	0.070	AXNA 7 32
5.8	7.4	7.9	21.0	13 000	469	130	100	7 x 1	0.090	AXNAT 7 42
5.8	7.4	7.9	21.0	13 000	469	130	100	7 x 1	0.067	AXNA 8 32
5.8	7.4	7.9	21.0	13 000	469	130	100	7 x 1	0.090	AXNAT 8 42
9.0	11.9	8.5	23.8	11 500	497	190	116	9 x 1	0.096	AXNA 9 35
9.0	11.9	8.5	23.8	11 500	497	190	116	9 x 1	0.120	AXNAT 9 45
9.7	13.1	9.0	26.5	10 500	525	180	119	10 x 1	0.109	AXNA 10 37
9.7	13.1	9.0	26.5	10 500	525	180	119	10 x 1	0.151	AXNAT 10 48
10.9	15.5	9.2	27.8	10 000	532	220	120	12 x 1,5	0.133	AXNA 12 40
10.9	15.5	9.2	27.8	10 000	532	220	120	12 x 1,5	0.160	AXNAT 12 50

1) 6% of dynamic axial load

2) with axial load equal to preload

3) rigidity of a single thrust bearing with load equal to preload

4) hexagon socket shallow head cap screw DIN 91

Precision combined bearings, with adjustable axial preload

AXNB and ARNB series

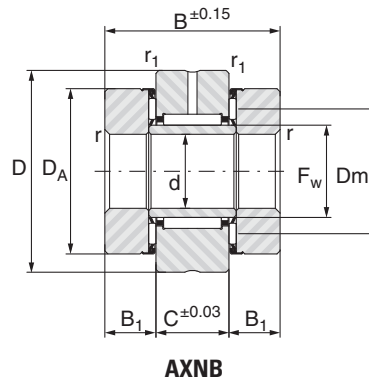

Shaft ∅ mm	Designation				d mm	D mm	F _w mm	D _A mm	D _m mm	B mm	C mm	B ₁ mm	r min.	r ₁ min.
	AXNB	ARNB series 1	ARNB series 2	ARNB series 3										
15	15 45				15	45	20	35	26.8	40	16	12	0.85	0.85
		15 45			15	45	20	35	26.8	46	16	15	0.85	0.85
20	20 52				20	52	25	42	32.5	40	16	12	0.85	0.85
		20 52			20	52	25	42	32.5	46	16	15	0.85	0.85
			20 62		20	62	30	52	39.9	60	20	20	1.3	0.85
25				20 72	20	72	30	60	43.5	60	20	20	1.3	0.85
	25 57				25	57	30	47	37.5	44	20	12	0.85	0.85
		25 57			25	57	30	47	37.5	50	20	15	0.85	0.85
			25 72		25	72	35	62	46.7	60	20	20	1.3	0.85
30				25 80	25	80	35	68	49.8	60	20	20	1.3	0.85
	30 62				30	62	35	53	43.1	44	20	12	0.85	0.85
		30 62			30	62	35	53.4	42.8	50	20	15	0.85	0.85
			30 80		30	80	40	68	52.7	66	20	23	1.3	0.85
35				30 90	30	90	40	78	57	66	20	23	1.3	0.85
	35 70				35	70	40	60	48.9	48	20	14	1.3	0.85
		35 70			35	70	40	60.4	48.8	54	20	17	1.3	0.85
			35 85		35	85	45	73	57.7	66	20	23	1.3	0.85
40				35 100	35	100	45	85	63	66	20	23	1.3	0.85
	40 75				40	75	45	65	53.9	48	20	14	1.3	0.85
		40 75			40	75	45	65.4	53.8	54	20	17	1.3	0.85
			40 90		40	90	50	78	62.7	75	25	25	1.3	0.85
45				40 110	40	110	50	95	70	75	25	25	1.3	0.85
	45 80				45	80	50	70	59.5	54	25	14.5	1.3	0.85
		45 80			45	80	50	70.4	58.8	60	25	17.5	1.3	0.85
			45 105		45	105	55	90	70.9	82	25	28.5	1.3	0.85
50				45 120	45	120	55	105	78.2	82	25	28.5	1.3	0.85
	50 90				50	90	55	78	65.5	54	25	14.5	1.3	0.85
		50 90			50	90	55	78.4	65.5	60	25	17.5	1.3	0.85
			50 110		50	110	60	95	75.9	82	25	28.5	1.3	0.85
55				50 125	50	125	60	110	83.2	82	25	28.5	1.3	0.85
			55 115		55	115	65	100	80.9	82	25	28.5	1.75	0.85
60				55 130	55	130	65	115	88.2	82	25	28.5	1.75	0.85
			60 120		60	120	70	105	85.9	82	25	28.5	1.75	0.85
65				60 120	60	140	70	125	96	82	25	28.5	1.75	0.85
			65 125		65	125	75	110	90.9	82	25	28.5	1.75	0.85
70					70	130	80	115	95.9	82	25	28.5	1.75	0.85
75					75	155	90	135	109.9	100	30	35	1.75	0.85
90					90	180	110	160	132.9	110	35	37.5	1.75	0.85

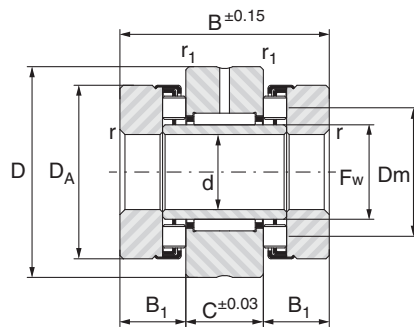

ARNB

Load Ratings kN				Speed rating min-1	Preload ¹⁾ N	Rotation ²⁾ torque Nmm	Rigidity K ³⁾ N/μm	Weight kg	Designation
radial		axial							
Dyn. C	Stat. Co	Dyn. C	Stat. Co						
16.2	22.0	12.0	40.0	9 000	735	120	1 250	0.296	AXNB 15 45
16.2	22.0	20.5	49.0	9 000	1 340	350	780	0.316	ARNB 15 45
18.9	28.8	13.5	50.0	7 500	820	160	1 480	0.392	AXNB 20 52
18.9	28.8	23.5	63.0	7 500	1 550	500	950	0.418	ARNB 20 52
28.0	44.5	48.0	115.0	6 300	3 010	1 200	1 130	0.875	ARNB 20 62
28.0	44.5	42.5	148.0	5 600	2 765	800	1 700	1.300	ARNB 20 72
28.0	44.5	14.8	58.5	6500	880	200	1 780	0.515	AXNB 25 57
28.0	44.5	24.8	70.0	6 500	1 620	550	1 090	0.543	ARNB 25 57
30.5	53.0	66.0	165.0	5 300	4 130	1 900	1 270	1.180	ARNB 25 72
30.5	53.0	48.0	179.0	4 900	3 060	1 000	1 900	1.565	ARNB 25 80
30.5	53.0	19.0	85.0	5 500	1 130	300	1 880	0.585	AXNB 30 62
30.5	53.0	32.0	88.0	5 500	2 100	850	1 070	0.620	ARNB 30 62
32.5	59.0	83.0	210.0	4 800	5 040	2 600	1 450	1.520	ARNB 30 80
32.5	59.0	68.0	250.0	4 200	4 340	1 600	2 300	2.145	ARNB 30 90
32.5	59.0	20 500	97.0	5 000	1 210	350	2 250	0.787	AXNB 35 70
32.5	59.0	45 000	124.0	5 000	2 910	1 350	1 300	0.815	ARNB 35 70
34.5	67.0	86 000	228.0	4 300	5 250	2 900	1 520	1.642	ARNB 35 85
34.5	67.0	90 000	328.0	3 800	5 770	2 400	2 500	2.535	ARNB 35 100
34.5	67.0	22.0	110.0	4 500	1 300	400	2 630	0.860	AXNB 40 75
34.5	67.0	47.5	138.0	4 500	3 070	1 550	1 470	0.908	ARNB 40 75
44.0	95.0	93.0	260.0	4 000	5 740	3 500	1 620	2.110	ARNB 40 90
44.0	95.0	106.0	420.0	3 400	6 750	3 200	3 000	3.570	ARNB 40 110
44.0	95.0	22.7	119.0	4 000	1 340	450	2 980	1.100	AXNB 45 80
44.0	95.0	50.0	150.0	4 000	3 230	1 750	1 480	1.232	ARNB 45 80
44.0	98.0	127.0	345.0	3 600	7 770	5 300	1 930	3.060	ARNB 45 105
44.0	98.0	122.0	520.0	3 100	7 700	4 100	3 400	4.700	ARNB 45 120
44.0	98.0	28.5	164.0	3 800	1 680	650	3 500	1.385	AXNB 50 90
44.0	98.0	60.0	197.0	3 800	3 800	2 350	1 950	1.440	ARNB 50 90
48.0	113.0	131.0	370.0	3 300	8 120	5 900	2 020	3.320	ARNB 50 110
48.0	113.0	128.0	560.0	2 900	8 050	4 600	3 450	4.945	ARNB 50 125
53.5	119.0	135.0	395.0	3 100	8 400	6 500	2 170	3.535	ARNB 55 115
53.5	119.0	134.0	610.0	2 800	8 330	4 900	3 750	5.256	ARNB 55 130
56.0	128.0	147.0	445.0	2 900	9 100	7 500	2 500	3.717	ARNB 60 120
56.0	128.0	174.0	710.0	2 600	10 640	6 800	4 100	5.976	ARNB 60 140
64.0	143.0	150.0	470.0	2 800	9 310	8 100	2 550	3.960	ARNB 65 125
73.0	148.0	155.0	495.0	2 600	9 520	8 800	2 720	4.136	ARNB 70 130
7.0	165.0	230.0	730.0	2 300	14 140	14 800	3 050	7.700	ARNB 75 155
118.0	268.0	288.0	990.0	1 900	17 640	22 200	3 700	11.654	ARNB 90 180

1) 6% of dynamic axial load - 2) with axial load equal to preload - 3) rigidity of a single thrust bearing with load equal to preload



Precision combined bearings, with adjustable axial preload

AXNBT and ARNBT
series

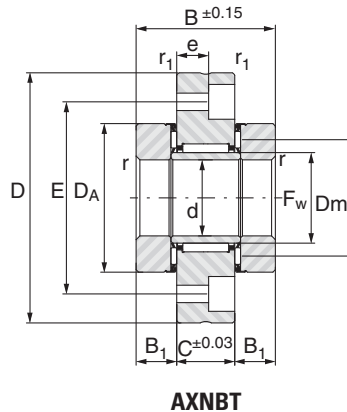

Shaft ∅ mm	Designation			d mm	D mm	F _w mm	D _A mm	D _m mm	B mm	C mm	B ₁ mm	r min.	r ₁ min.	Screw TCEI ⁴⁾ class 12,9	Mounting			Torque Nm
	AXNBT	ARNBT series 1	ARNBT series 2												N° viti	E mm	e mm	
15	15 60			15	60	20	35	26.8	40	16	12	0.85	0.85	6x20	6	46	9	10
		15 60		15	60	20	35	26.8	46	16	15	0.85	0.85	6x20	6	46	9	10
20	20 68			20	68	25	42	32.5	40	16	12	0.85	0.85	6x20	8	53	9	10
		20 68		20	68	25	42	32.5	46	16	15	0.85	0.85	6x20	8	53	9	10
			20 80	20	80	30	52	39.9	60	20	20	1.30	0.85	6x25	12	63	13	10
25	25 75			25	75	30	47	37.5	44	20	12	0.85	0.85	6x25	8	58	13	10
		25 75		25	75	30	47	37.5	50	20	15	0.85	0.85	6x25	8	58	13	10
			25 90	25	90	35	62	46.7	60	20	20	1.30	0.85	6x25	12	73	13	10
30	30 80			30	80	35	53	43.1	44	20	12	0.85	0.85	6x25	12	63	13	10
		30 80		30	80	35	53.4	42.8	50	20	15	0.85	0.85	6x25	12	63	13	10
			30 105	30	105	40	68	52.7	66	20	23	1.30	0.85	8x25	12	85	11	24
35	35 90			35	90	40	60	48.9	48	20	14	1.30	0.85	6x25	12	73	13	10
		35 90		35	90	40	60.4	48.8	54	20	17	1.30	0.85	6x25	12	73	13	10
			35 110	35	110	45	73	57.7	66	20	23	1.30	0.85	8x25	12	88	11	24
40	40 100			40	100	45	65	53.9	48	20	14	1.30	0.85	8x25	8	80	11	24
		40 100		40	100	45	65.4	53.8	54	20	17	1.30	0.85	8x25	8	80	11	24
			40 115	40	115	50	78	62.7	75	25	25	1.30	0.85	8x30	12	94	16	24
45	45 105			45	105	50	70	59.5	54	25	14.5	1.30	0.85	8x30	8	85	16	24
		45 105		45	105	50	70.4	58.8	60	25	17.5	1.30	0.85	8x30	8	85	16	24
			45 130	45	130	55	90	70.9	82	25	28.5	1.30	0.85	8x30	12	105	16	24
50	50 115			50	115	55	78	65.5	54	25	14.5	1.30	0.85	8x30	12	94	16	24
		50 115		50	115	55	78.4	65.5	60	25	17.5	1.30	0.85	8x30	12	94	16	24
			50 140	50	140	60	95	75.9	82	25	28.5	1.75	0.85	10x30	12	113	14	48
55			55 145	55	145	65	100	80.9	82	25	28.5	1.75	0.85	10x30	12	118	14	48
60			60 150	60	150	70	105	85.9	82	25	28.5	1.75	0.85	10x30	12	123	14	48
65			65 155	65	155	75	110	90.9	82	25	28.5	1.75	0.85	10x30	12	128	14	48
70			70 160	70	160	80	115	95.9	82	25	28.5	1.75	0.85	10x30	12	133	14	48
75			75 185	75	185	90	135	109.9	100	30	35	1.75	1.30	12x35	12	155	17	80
90			90 210	90	210	110	160	132.9	110	35	37.5	1.75	1.30	12x40	16	180	22	80

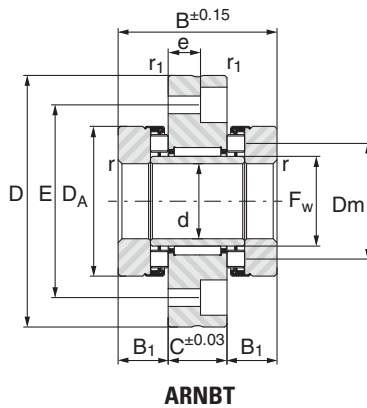

Load Ratings kN				Speed rating min-1	Preload ¹⁾ N	Rotation ²⁾ torque Nmm	Rigidity K ³⁾ N/μm	Weight kg	Designation
radial		axial							
Dyn. C	Stat. Co	Dyn. C	Stat. Co						
16.2	22.0	12.0	40.0	9 000	735	120	1 250	0.406	AXNBT 15 60
16.2	22.0	20.5	49.0	9 000	1 340	350	780	0.427	ARNBT 15 60
18.9	28.8	13.5	50.0	7 500	820	160	1 480	0.521	AXNBT 20 68
18.9	28.8	23.5	63.0	7 500	1 550	500	950	0.548	ARNBT 20 68
28.0	44.5	48.0	115.0	6 300	3 010	1 200	1 130	1.088	ARNBT 20 80
28.0	44.5	14.8	58.5	6 500	880	200	1 780	0.740	AXNBT 25 75
28.0	44.5	24.8	70.0	6 500	1 620	550	1 090	0.768	ARNBT 25 75
30.5	53.0	66.0	165.0	5 300	4 130	1 900	1 270	1.438	ARNBT 25 90
30.5	53.0	19.0	85.0	5 500	1 130	300	1 880	0.798	AXNBT 30 80
30.5	53.0	32.0	88.0	5 500	2 100	850	1 070	0.833	ARNBT 30 80
32.5	59.0	83.0	210.0	4 800	5 040	2 600	1 450	1.876	ARNBT 30 105
32.5	59.0	20.5	97.0	5 000	1 210	350	2 250	1.079	AXNBT 35 90
32.5	59.0	45.0	124.0	5 000	2 910	1 350	1 300	1.108	ARNBT 35 90
34.5	67.0	86.0	228.0	4 300	5 250	2 900	1 520	2.029	ARNBT 35 110
34.5	67.0	22.0	110.0	4 500	1 300	400	2 630	1.257	AXNBT 40 100
34.5	67.0	47.5	138.0	4 500	3 070	1 550	1 470	1.306	ARNBT 40 100
44.0	95.0	93.0	260.0	4 000	5 740	3 500	1 620	2.657	ARNBT 40 115
44.0	95.0	22.7	119.0	4 000	1 340	450	2 980	1.652	AXNBT 45 105
44.0	95.0	50.0	150.0	4 000	3 230	1 750	1 480	1.684	ARNBT 45 105
44.0	98.0	127.0	345.0	3 600	7 770	5 300	1 930	3.723	ARNBT 45 130
44.0	98.0	28.5	164.0	3 800	1 680	650	3 500	1.932	AXNBT 50 115
44.0	98.0	60.0	197.0	3 800	3 800	2 350	1 950	1.987	ARNBT 50 115
48.0	113.0	131.0	370.0	3 300	8 120	5 900	2 020	4.091	ARNBT 50 140
53.5	119.0	135.0	395.0	3 100	8 400	6 500	2170	4.353	ARNBT 55 145
56.0	128.0	147.0	445.0	2 900	91 00	7 500	2 500	4.581	ARNBT 60 150
64.0	143.0	150.0	470.0	2 800	9 310	8 100	2 550	4.871	ARNBT 65 155
73.0	148.0	155.0	495.0	2 600	9 520	8 800	2 720	5.093	ARNBT 70 160
77.0	165.0	230.0	730.0	2 300	14 140	14 800	3 050	8.915	ARNBT 75 185
118.0	268.0	288.0	990.0	1 900	17 640	22 200	3 700	13.200	ARNBT 90 210

1) 6% of dynamic axial load

2) with axial load equal to preload

3) rigidity of a single thrust bearing with load equal to preload

4) hexagon socket shallow head cap screw DIN 91

